

B.TECH
(SEM I) THEORY EXAMINATION 2022-23
BASIC ELECTRICAL ENGINEERING

Time: 3 Hours

Total Marks: 100

Note: Attempt all Sections. If require any missing data; then choose suitably.

SECTION A

- 1. Attempt all questions in brief. 10 x2 = 20**
- Explain Unilateral and Bilateral Elements with example.
 - Explain the source transformation technique.
 - What is the problem of low power factor?
 - What do you mean by Bandwidth & quality factor in series RLC circuit?
 - Why the transformer is also called the static device?
 - How can eddy current loss be minimized?
 - What is need of commutator?
 - What is value of slip when rotor is standstill; rotate at synchronous speed in 3 phase induction motor?
 - Why Earthing is provided?
 - What are the factors that affect the battery capacity?

SECTION B

- 2. Attempt any three of the following; 3x10=30**
- Find Thevenin's equivalent to the left of the terminal AB as shown in Fig.1

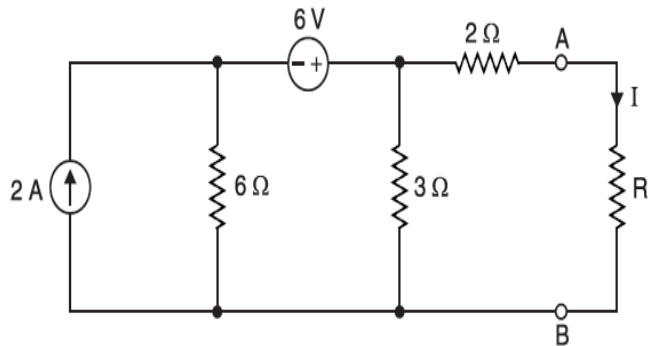

Fig. 1

- Describe the phasor relationship between current and voltage for (i) an inductor, and (ii) a capacitor.
A voltage $v(t) = 220 \sqrt{2} \sin 100 t$ is applied to the circuit shown. What is the rms value of current through the resistor R of 100Ω ?
- A single-phase, 150 KVA, 5000 V/250 V, 50 Hz transformer has the full load copper losses of 1.8 KW and core losses of 1.5 KW. Find (i) the number of turns in each winding for a maximum core flux of 60 mWb, (ii) the efficiency at full rated KVA, with power factor of 0.8 lagging, (iii) the efficiency at half the rated KVA, with unity power factor, and (iv) the KVA load for maximum efficiency.
- Explain the working principle and applications of single phase shaded pole motors. It is possible to reverse the direction of rotation of such a motor? If yes, how? If not, why?
- What are the different types of cables? Briefly give their construction and application.

SECTION C

3. Attempt any one part of the following: **1x10=10**

- (a) State and explain superposition theorem. For the circuit shown in Fig.(2), find the power dissipated in 9Ω resistance using superposition theorem.

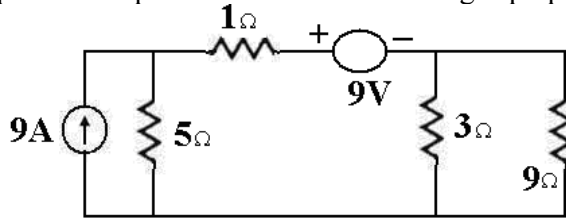

Fig (2)

- (b) What is the criterion for star-Delta transformation? Develop the relationship for delta-to-star and star-to-delta transformation.

4. Attempt any one part of the following: **1x10=10**

- (a) Explain Series Resonance in RLC circuit? A circuit of a resistance of 10Ω , and inductance of 0.1 H and a variable capacitance in series across a 230 V , 50 Hz supply. Calculate : (i) The value of capacitance to produce resonance (ii) The voltage across the capacitance and inductance. (iii) The Q-factor of the circuit.
- (b) Derive the relation between line and phase voltage and current for a delta connected 3 phase balanced system. A balanced delta-connected load of impedance, $Z=20 \angle 50^\circ \Omega$ is connected to line voltage of 440 V . Obtain the currents and power supplied to load.

5. Attempt any one part of the following: **1x10=10**

- (a) Derive the EMF equation of a single phase transformer. Explain various losses occurring in transformer.
- (b) How is B-H curve of a ferromagnetic material different from that of a non-magnetic material? Draw and name all the salient regions of B-H curve of magnetic material.

6. Attempt any one part of the following: **1x10=10**

- (a) What are the different types of dc motors? Also write the applications of each. A dc shunt generation delivers 50 KW at 250 V and 400 rpm . The armature and field resistances are $0.02\ \Omega$ and $50\ \Omega$ respectively. Calculate the speed of the machine running as shunt motor and taking 50 KW input at 250 V . Allow brush contact drop of 1 V per brush.
- (b) Explain the principle of rotating flux in three phase induction motor also explain & draw the torque- slip characteristics.

7. Attempt any one part of the following: **1x10=10**

- (a) What is MCCB and how does it differ from MCB? Explain its operation mechanism.
- (b) What are the primary and secondary battery? Explain different types of battery with construction and working with neat diagrams.