



Roll No:

--	--	--	--	--	--	--	--	--	--	--	--	--	--	--	--	--	--	--	--

**BTECH**  
**(SEM I) THEORY EXAMINATION 2023-24**  
**EMERGING DOMAIN IN ELECTRONICS ENGINEERING**

TIME: 3HRS

M.MARKS: 100

**Note: 1.** Attempt all Sections. If require any missing data; then choose suitably.

**SECTION A**

**1. Attempt all questions in brief.**

Qno.	Question	Marks	CO
a.	What is the depletion layer in a semiconductor diode?	2	1
b.	What is the function of a varactor diode?	2	1
c.	How does a BJT amplify signals?	2	2
d.	Name the three configurations of a BJT.	2	2
e.	Briefly explain the concept of IoT and its key components.	2	3
f.	Describe the role of Bluetooth in IoT systems.	2	3
g.	How Boolean algebra is used in simplifying logic functions?	2	4
h.	Differentiate between SSI, MSI, LSI, and VLSI integrated circuits.	2	4
i.	Give applications of amplitude modulation (AM).	2	5
j.	What are the elements of satellite communication systems?	2	5

**SECTION B**

**2. Attempt any three of the following:**

Qno.	Question	Marks	CO
a.	Describe the V-I characteristics of a semiconductor diode. Differentiate between the behavior of the diode in forward bias and reverse bias.	10	1
b.	Differentiate between common base, common emitter, and common collector configurations of a BJT.	10	2
c.	Provide an introduction to operational amplifiers (op-amps), highlighting their basic properties and ideal behavior. Discuss the significance of op-amps in various practical circuits.	10	3
d.	Discuss the evolution of integrated circuit (IC) technology from small-scale integration (SSI) to very large-scale integration (VLSI).	10	4
e.	Describe the elements of a communication system, including transmitters, receivers, channels, and noise sources. Discuss the challenges associated with each element.	10	5

**SECTION C**

**3. Attempt any one part of the following:**

Qno.	Question	Marks	CO
a.	Explain the breakdown mechanisms in Zener diodes, including Zener breakdown and avalanche breakdown. How do these mechanisms differ in terms of voltage regulation and reliability?	10	1
b.	With help of neat circuit diagrams, explain the working of a full wave bridge rectifier.	10	1



Roll No:

--	--	--	--	--	--	--	--	--	--	--	--	--	--	--	--	--	--	--	--

**BTECH**  
**(SEM I) THEORY EXAMINATION 2023-24**  
**EMERGING DOMAIN IN ELECTRONICS ENGINEERING**

TIME: 3HRS

M.MARKS: 100

**4. Attempt any one part of the following:**

Qno.	Question	Marks	CO
a.	Discuss the construction, characteristics, and operating principles of metal-oxide-semiconductor field-effect transistors (MOSFETs).	10	2
b.	With help of a neat diagram, explain the working of a voltage doubler circuit.	10	2

**5. Attempt any one part of the following:**

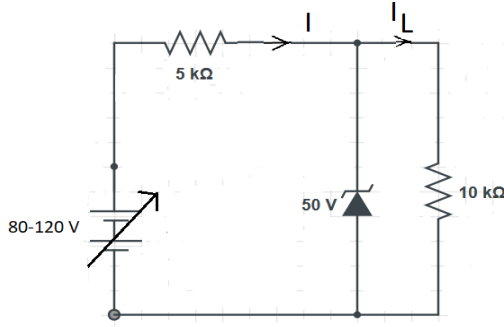
Qno.	Question	Marks	CO
a.	For the circuit shown below, determine the value of maximum and minimum zener diode current. 	10	3
b.	With help of the circuit diagram, explain the working of OPAMP as differentiator.	10	3

**6. Attempt any one part of the following:**

Qno.	Question	Marks	CO
a.	Explain the working of liquid crystal displays with help of a neat diagram.	10	4
b.	Simplify the following function using K map $F(A, B, C, D) = \sum(1, 3, 4, 5, 6, 7, 9, 11, 13, 15)$ Also implement the simplified function using basic gates only.	10	4

**7. Attempt any one part of the following:**

Qno.	Question	Marks	CO
a.	Discuss the goals and applications of data communication networks. Explain the importance of network communication in modern society.	10	5
b.	Discuss the need for modulation in communication systems. Explain the fundamentals of amplitude modulation (AM) and demodulation techniques.	10	5