

Roll No:

--	--	--	--	--	--	--	--	--	--	--	--

BTECH
(SEM I) THEORY EXAMINATION 2023-24
BASIC ELECTRICAL ENGG

TIME: 3HRS

M.MARKS: 100

Note: 1. Attempt all Sections. If require any missing data; then choose suitably.

SECTION A

1. Attempt all questions in brief.

Q no.	Question	Marks	CO
a.	Define (i) Active and Passive elements, (ii) Linear and Non-linear elements.	2	1
b.	Describe the following elements briefly: (i) Independent Ideal Voltage Source (ii) Independent Ideal Current Source	2	1
c.	Define power factor and reactive power.	2	2
d.	A series circuit with $R = 10 \Omega$, $L = 10 \text{ mH}$, and $C = 100 \text{ pF}$ is connected across 180V variable frequency source. Calculate the value of current at resonance and the resonant frequency.	2	2
e.	A coil has 400 turns, find the induced voltage in it, if the flux changes from 0.2mWb to 1mWb in 0.2 seconds?	2	3
f.	What will happen if DC supply is applied to the transformer?	2	3
g.	What is the generated EMF in DC generator?	2	4
h.	What is the function of slip-rings in 3- ϕ induction motor?	2	4
i.	What are the differences between primary and secondary batteries?	2	5
j.	In what way, a MCB is better than a Fuse.	2	5

SECTION B

2. Attempt any three of the following:

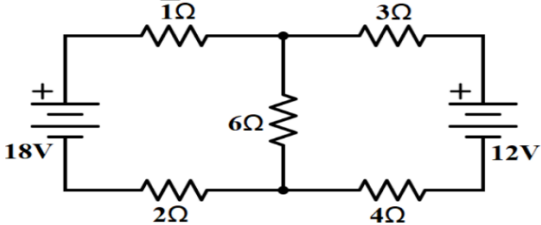
Q no.	Question	Marks	CO
a.	Calculate the current across 3Ω resistor in the following circuit using Nodal Analysis: 	10	1
b.	A 10 mH coil is connected in series with a loss free capacitor to a variable frequency source of 30 V. The current in the circuit has a maximum value of 0.3 A at a frequency of 100 kHz. Calculate (i) the value of capacitance to produce resonance, (ii) Q-factor of the coil, (iii) Half power frequencies.	10	2
c.	Derive an expression of EMF equation of transformer. A 25 KVA transformer has 250 turns on primary and 40 turns on secondary. The primary is supplied with 1500 V, 50 Hz alternating supply. Calculate (i) The rated primary and secondary currents, (ii) maximum flux in the core.	10	3
d.	Why 1- ϕ induction motor is not self-starting? What are the different methods of starting? Explain any one of them.	10	4
e.	Explain the importance of earthing. Also explain the different methods of earthing with neat and labelled diagram.	10	5

SECTION C

3. Attempt any one part of the following:

Q no.	Question	Marks	CO
a.	Derive an expression for the conversion of star to delta and delta to star transformation.	10	1



Roll No:

--	--	--	--	--	--	--	--	--	--	--	--	--	--	--	--	--	--	--	--

BTECH
(SEM I) THEORY EXAMINATION 2023-24
BASIC ELECTRICAL ENGG

TIME: 3HRS

M.MARKS: 100

b.	Calculate the current across the terminal AB using thevenin's theorem in the following circuit:	10	1

4. Attempt any one part of the following:

Q no.	Question	Marks	CO
a.	A balanced delta connected load of $(12+j9) \Omega$ /phase is connected to 3- ϕ , 400V supply. Find: (i) Line current, (ii) Power factor, (iii) power drawn from the supply, (iv) Reactive volt-ampere, and (v) Total volt-ampere.	10	2
b.	A voltage $v = 100\sin 314t$ is applied to a circuit consisting of a 25Ω resistor and an $80\mu\text{F}$ capacitor in series. Determine (i) Peak value of current, (ii) power factor and (iii) total power consumed in the circuit.	10	2

5. Attempt any one part of the following:

Q no.	Question	Marks	CO
a.	Briefly explain the different magnetic materials with example.	10	3
b.	A 100 kVA, 1- ϕ transformer has an iron loss of 600 W and a copper loss of 1.5 kW at full-load current. Calculate the efficiency at (i) full load and 0.8 power factor (lagging), (ii) Half-load and unity power factor, (iii) Load corresponding to maximum efficiency.	10	3

6. Attempt any one part of the following:

Q no.	Question	Marks	CO
a.	A 3- ϕ induction motor has 2 poles and is connected to 400V, 50 Hz supply. Calculate the actual rotor speed and the rotor frequency when the slip is 4%. Also calculate the speed of rotating magnetic field when the machine is replaced with 4 pole machine.	10	4
b.	A DC shunt machine connected to 230V supply has armature resistance of 0.115Ω and shunt field winding resistance of 115Ω . Find the ratio of the speed as a generator to the speed as a motor with the line current in each case being 100 A.	10	4

7. Attempt any one part of the following:

Q no.	Question	Marks	CO
a.	With the help of diagram, explain the working principle of following: (i) Miniature circuit breaker, (ii) Switch fuse unit.	10	5
b.	How do you calculate energy consumption per kWh? Calculate the electricity bill amount for a leap year, if the following devices are used as specified. (A) 3 Bulbs of 40W for 6 hours per day (B) 4 Tube lights of 50W for 8 hours per day Given the rate of electricity is Rs 8 per unit.	10	5