

Roll No: 

--	--	--	--	--	--	--	--	--	--	--	--	--	--	--	--	--	--	--

**BTECH**  
**(SEM I) THEORY EXAMINATION 2024-25**  
**BASIC ELECTRICAL ENGG**

TIME: 3 HRS

M.MARKS: 100

**Note:** Attempt all Sections. In case of any missing data; choose suitably.**SECTION A****1. Attempt all questions in brief.****2 x 10 = 20**

Q no.	Question	Marks	CO
a.	What is ideal current source.	2	1
b.	Differentiate between mesh and loop	2	1
c.	Define active power.	2	2
d.	Write the significance of power factor.	2	2
e.	What is eddy current in transformer.	2	3
f.	Define magnetic circuit.	2	3
g.	Classify the DC motor.	2	4
h.	What is the need of starter.	2	4
i.	Define earthing.	2	5
j.	Define fuse.	2	5

**SECTION B****2. Attempt any three of the following:****10 x 3 = 20**

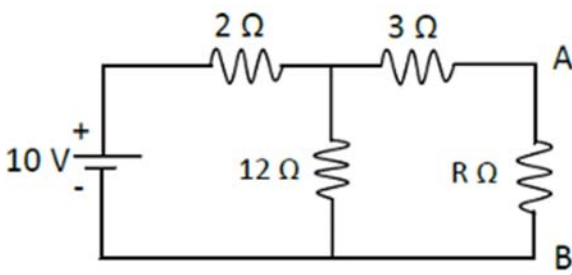
Q no.	Question	Marks	CO
a.	Draw the Norton's equivalent circuit for the circuit shown in figure 	10	1
b.	An unbalanced four wire star connected load has a balanced voltage of 400V, the loads are $Z_1=(4+j8)\Omega$ , $Z_2=(3+j4)$ and $Z_3=(15+j20)\Omega$ . Calculate the (i) Line currents (ii) Currents in the neutral wire and (iii) Total power.	10	2
c.	Explain Construction of Single Phase Transformer With Neat Diagram?	10	3
d.	Discuss about the principle of operation of DC motors.	10	4
e.	What are the main differences between single-core and multi-core cables? Where are each typically used?	10	5

**SECTION C****3. Attempt any one part of the following:****10 x 1 = 10**

Q no.	Question	Marks	CO
a.	Find the Thevenin's equivalent for the circuit shown below	10	1



Roll No:

--	--	--	--	--	--	--	--	--	--	--	--	--	--	--	--	--	--	--	--

**BTECH**  
**(SEM I) THEORY EXAMINATION 2024-25**  
**BASIC ELECTRICAL ENGG**

TIME: 3 HRS

M.MARKS: 100

b.	Three resistances of values $20\Omega$ , $30\Omega$ and $50\Omega$ are connected in series across $20\text{ V DC}$ supply. Calculate, i) Equivalent resistance of the circuit. ii) Total current from the supply. iii) Voltage drop across each resistor. iv) Power dissipated in each resistor.	10	1

**4. Attempt any one part of the following: 10 x 1 = 10**

Q no.	Question	Marks	CO
a.	Derive the voltage and current relations in three phase balanced circuits for star connection.	10	2
b.	Explain resonance for series RLC circuit and derive the equation for resonant frequency	10	2

**5. Attempt any one part of the following: 10 x 1 = 10**

Q no.	Question	Marks	CO
a.	Explain Three Phase Transformer Connection.	3	3
b.	A $125\text{ KVA}$ transformer having primary voltage of $2000\text{V}$ at $50\text{ Hz}$ has $182$ primary and $40$ secondary turns. Neglecting losses, Calculate (i)The full load primary and secondary currents.(ii)The no load secondary induced emf (iii)Maximum flux in the core	3	3

**6. Attempt any one part of the following: 10 x 1 = 10**

Q no.	Question	Marks	CO
a.	Explain equivalent circuit for single phase induction motor.	4	4
b.	Define significance of torque slip characteristics of 3-phase induction motor	4	4

**7. Attempt any one part of the following: 10 x 1 = 10**

Q no.	Question	Marks	CO
a.	Why is earthing important in electrical systems, particularly in LT switchgear? Describe at least two types of earthing methods.	5	5
b.	Write note on (i) MCCB (ii) ELCB	5	5